



RR-16

RR-30

- hydraulické nitovačky
- stolové a stojanové prevedenie (stôl dostupný iba na dopyt)

PRÍSLUŠENSTVO

- počítadlo súčiastok
- dvojrúčné ovládanie s bezpečnostným relé
- nastaviteľný zdvih
- regulátor prítlaku s manometrom

TECHNICKÉ ÚDAJE

- napájanie 380 V (50 Hz)
- ovládacie napätie 24 V DC



(1)

- ďalšie nitovacie nástroje (1)
- manuálny (2) alebo pneumatický (3) posun
- gumený (4) alebo kovový (5) držiak na uchytenie polohy súčiastky na doske
- systém automatického mazania (6) nitovacej hlavy



(2)



(3)



(4)



(5)



(6)

TECHNICKÉ ÚDAJE		RR-16	RR-16 PB	RR-16 CE	RR-20	RR-20 CE	RR-30
Max. priemer (oceľ pri 40 kg/mm ²)	mm	16	16	16	20	20	30
Nastaviteľný zdvih nitovania	mm	5-50	5-50	5-50	5-50	10-100	10-100
Hydraulický tlak	bar	40	40	40	65	65	65
Nastaviteľný čas nitovania	sek.	0-5	0-5	0-5	0-5	0-5	0-5
Inštalovaný výkon	kW	2,4	2,4	2,4	2,8	2,8	4,5
4 jazyky ovládania (EN, DE, ES, FR)	—	✓	✓	✓	✓	✓	✓
Váha	kg	340	445	285	445	292	720

FUNKČNÉ ROZMERY

RR-16

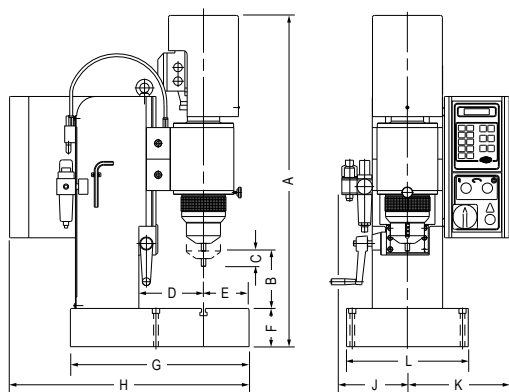

RR-30

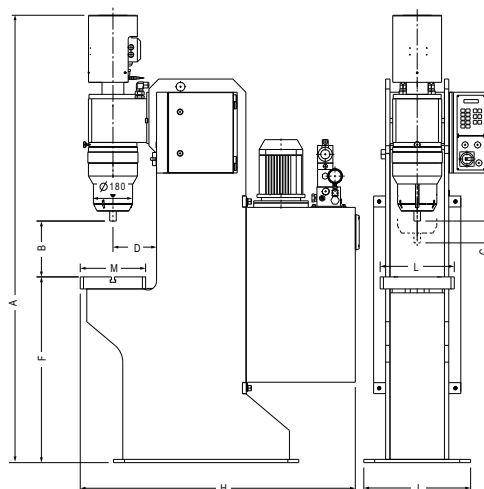

RR-16 PB
RR-20

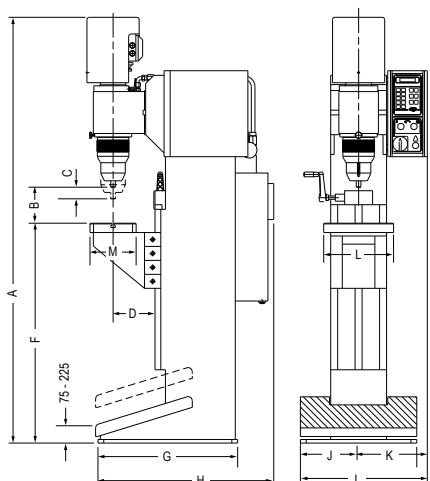

RR-16/20 CE

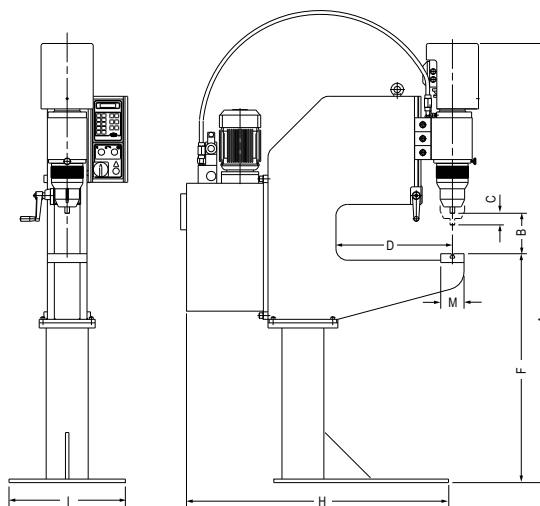

ROZMERY	RR-16	RR-16 PB	RR-16 CE	RR-20	RR-20 CE	RR-30
A	915-1115	1830	1780-1980	1860	1775-1975	2050
B	60-260	60-500	60-260	60-500	60-260	255
C	5-50	5-50	5-50	5-50	5-50	10-100
D	180	180	500	180	500	200
E	125	—	—	100	—	150
F	125	660-1100	984	660-1100	984	850
G	525	600	—	600	—	850
H	650	755	1275	775	1280	1280
I	840	500	500	500	500	490
J	200	255	255	250	255	245
K	315	270	270	295	270	350
L	350	300	170	300	300	340
M	—	198	100	200	100	300
T	M10	M10	M10	M10	M10	M12